

## HFRL-508 60 CFM Filter-Regulator HAF-502 100 CFM Filter

**IMPORTANT:**  
Read and follow all instructions and **SAFETY PRECAUTIONS** before using this equipment. Retain for future reference.

### WARNING

**Risk of personal injury.  
Risk of property damage.**

Except as otherwise specified by the manufacturer, this product is specifically designed for compressed air service and use with any other fluid (liquid or gas) is a misapplication. For example, use with or injection of certain hazardous gases in the system (such as oxygen or liquid petroleum gas) could be harmful to the unit or result in a combustible condition that may cause fire or explosion. Manufacturer's warranties are void in the event of misapplication and manufacturer assumes no responsibility for any resulting loss.

### DESCRIPTION

This 100 CFM filter (Model HAF-502) is designed to remove dirt, pipe scale and most liquid aerosol. It includes a 5 micron filter element. A model with 50 CFM air regulator is also available (Model HFRL-508).

### Specifications

#### Air Filter:

Air Inlet	1/2" NPT(F)
Air Outlet	1/2" NPT(F)
Air Flow Capacity	100 CFM
Maximum Temp.	150° F (65.6° C)
Max. Inlet Pressure	150 psig (10.3 bar)
Max. Operating Pressure	150 psig (10.3 bar)

#### Air Connections Model HFRL-508:

Regulated	Non-Regulated
(1) 1/4" NPS(M)	(1) 1/4" NPS(M)
(1) Plugged Port	

### INSTALLATION



### WARNING

**Risk of injury. Release all air pressure from system before servicing system. Do not place unit in service without metal bowl guard installed. Plastic bowl units are sold only with metal bowl guards. To minimize the danger of flying fragments in the event of plastic bowl failure, guard must not be removed. If the unit is in service without the metal bowl guard installed, manufacturer's warranties are void and the manufacturer assumes no responsibility for a resulting loss. If unit has been in service and does not have a metal bowl guard, order one and install before placing back in service.**

### CAUTION

**Certain solvents, paints and chemicals may attack plastic bowl and can cause bowl failure. Do not use near these materials.**

1. Be sure to read all "**WARNINGS**" and "**CAUTIONS**" in this manual and on the unit before installation or using this equipment.
2. Install filter as close as possible to point where air is being used. Install main air shut-off valve and standard pipe union (supplied by user) upstream of filter to allow maintenance to unit.
3. Install unit with air flow through filter in direction of arrow on top of unit.
4. Minimum 1/2" piping is recommended. Avoid using fittings, couplings, etc. that restrict air flow.
5. A 1/2" street elbow will be needed to allow vertical pipe installation. Mount filter in a vertical position.
6. Do not install filter in an application where the pressure drop will exceed 20 psi. For example, a quick opening valve located upstream from the filter could cause a momentary pressure drop in excess of 20 psi.
7. Install "T" handle into regulator (Model HFRL-508).
8. Maximum inlet pressure and operating temperature is: 150 PSIG (10.3 bar) and 150° F (65.6° C).
9. A 6' length of vinyl tubing is shipped loose with the unit. Slide over automatic drain which protrudes from bottom of bowl. Place other end of vinyl tubing into appropriate receptacle (i.e. below booth grating, can, etc.). Prevent vinyl tubing from becoming kinked which would prevent free movement of liquids discharged from the automatic drain.
10. An optional manual drain (HAF-11) is supplied loose in the carton (see item 10, Fig. 2). If desired, this can be installed in place of the automatic drain.

### OPERATION

After unit is installed and ready to use:

1. Attach air hose(s) to outlet ball valve(s), selecting regulated and/or non-regulation according to the application.
2. Open main shut-off valve upstream of filter.
3. Main line air pressure is monitored by the top air gauge.
4. Adjust regulator to desired setting by turning "T" handle in or out.
5. Open ball valve(s) to supply air to spray gun or tool being used. With air flowing, readjust air pressure at regulator if necessary.
6. After use, shut off ball valve(s) and bleed off residual air in hose(s).

### MAINTENANCE

### CAUTION

**Certain solvents, paints and chemicals may attack plastic bowl and can cause bowl failure. Do not use near these materials. When bowl becomes dirty, wipe only with a clean, dry cloth. Immediately replace any crazed, cracked, damaged or deteriorated plastic bowl with a new plastic bowl. Reinstall metal bowl guard.**

1. If bowl is equipped with manual drain, drain bowl at least once per shift. Units with automatic drain will drain automatically.
2. Before performing maintenance on unit, close main shut-off valve located upstream of filter. Bleed off residual air in unit.
3. To open filter, press button located on clamp ring and rotate ring either clockwise or counterclockwise. The metal bowl guard and plastic bowl can then be removed from the filter head.

4. Remove the filter element by loosening the baffle counter-clockwise. Clean or replace the filter element. The element can be cleaned by blowing off with a duster gun (clean from inside out). Frequency of element cleaning/replacement will depend upon air quality, air usage, and condition of the air piping. It is recommended to check and clean/replace the element every 3-6 months.
5. Inspect o-ring (2) for damage. Replace if necessary.
6. Inspect plastic bowl for signs of damage such as cracks, crazing or deterioration. Replace if necessary. See "Caution" at beginning of "Maintenance" section, page 1.

**Note**

Do not wash plastic bowl with the automatic drain installed. Water can get into the float mechanism, causing the drain to malfunction. Remove the automatic drain before cleaning the plastic bowl with soap and water (no solvents).

**WARNING**

**Do not place unit in service without metal bowl guard installed.**

7. Before placing unit back into service, make sure plastic bowl and metal bowl guard are properly installed and securely locked in place.
8. Confirm automatic drain operates properly after unit is in operation. Replace if necessary.

**CA PROP  
65**

**PROP 65 WARNING**

WARNING: This product contains chemicals known to the State of California to cause cancer and birth defects or other reproductive harm.

**FIGURE 1 MODEL HFRL-508 FILTER/REGULATOR (60 CFM)**

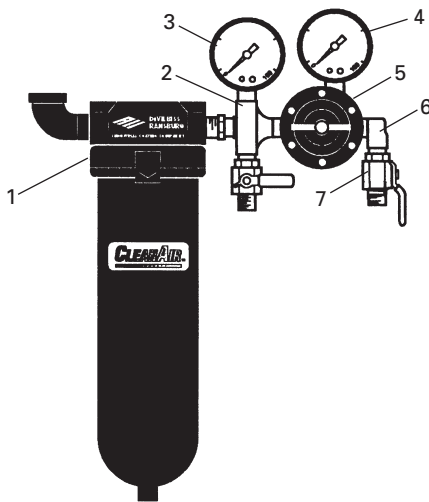

**PARTS LIST - Model HFRL-508**

Ref No.	Replacement Part No.	Description	Ind. Parts Req.
1	HAF-502	Air Filter, 100 CFM, See Fig.2	1
2	HAF-21	Cross Manifold	1
3	GA-288	Air Gauge, 0-160 psi (main line)	1
4	83-2727	Air Gauge, 0-100 psi (regulated)	1
5	HAR-507	Air Regulator (See Fig. 3)	1
6	—	1/4" Street Elbow, 90°	1
7	VA-542	Ball Valve	2

**FIGURE 2 MODEL HAF-502 FILTER (100 CFM)**

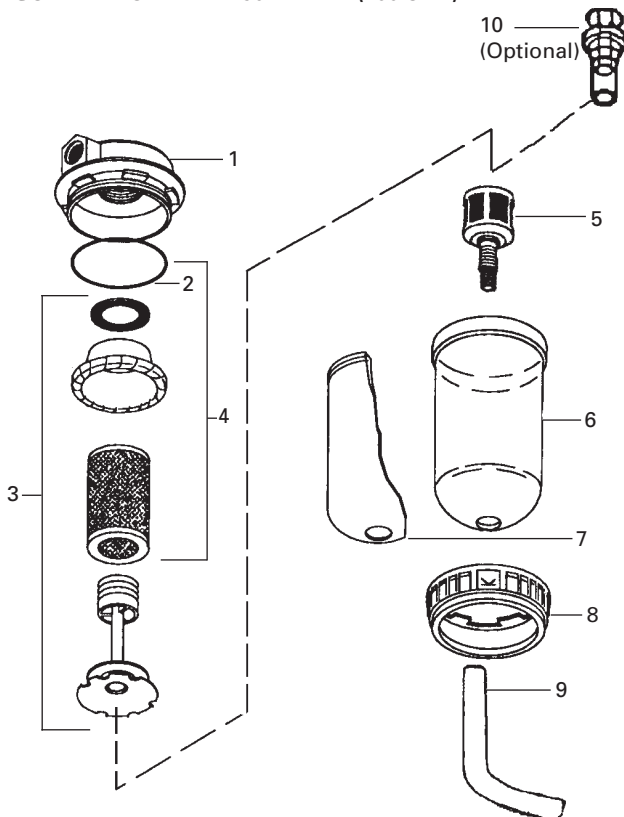

**PARTS LIST - Model HAF-502**

Ref No.	Replacement Part No.	Description	Ind. Parts Req.
1	—	Cover	1
2	—	O-Ring	1
3	HAF-26	Baffle Kit	1
4	HAF-6	Filter and O-Ring Kit	1
5	HAF-18	Automatic Drain (Std.)	1
6	HAF-8	Plastic Bowl	1
7	HAF-19	Metal Bowl Guard	1
8	HAF-409	Clamp Ring	1
9	—	1/2 x 3/8 Vinyl Tubing, 6 ft.	1
10	HAF-11	Manual Drain (Optional, shipped loose)	1

FIGURE 3 HAR-507 AIR REGULATOR, 60 CFM

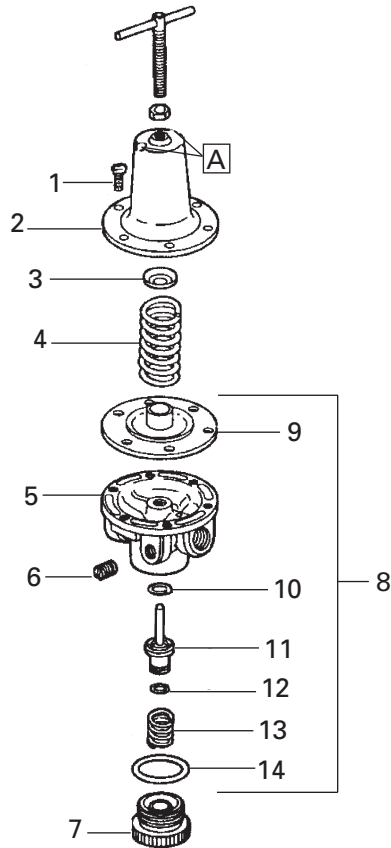

PARTS LIST - Model HAR-507 Regulator Assembly

Ref No.	Replacement Part No.	Description	Individual Parts Required
1	---	#10-32 x 9/16 Fillister Hd. Screw	6
2	HAR-14	Cover	1
3	---	Spring Button	1
4	---	Diaphragm Spring	1
5	---	Body	1
6	---	Pipe Plug 1/4" NPT(M)	1
7	---	Bottom Plug	1
8	KK-4977	Repair Kit (includes Items 9 thru 14)	1
9	---	Diaphragm Assembly	1
10	---	O-Ring	1
11	---	Valve	1
12	---	O-Ring	1
13	---	Spring	1
14	---	O-Ring	1

**REGULATOR MAINTENANCE**

1. Occasionally remove bottom plug (7) and clean valve seat (11) and body. Clean parts with denatured alcohol, wipe off seat and blow out body with compressed air.
2. To disassemble regulator, remove screws, bonnet, spring and spring button. Diaphragm assembly can now be removed.
3. Check all o-rings for signs of damage. Replace if necessary.
4. Reassemble parts. Center stem of valve in hole of regulator body. Screw bottom plug into body.

**Note**

Erratic operation or loss of regulation is usually due to dirt in the valve area and cleaning is necessary. If cleaning does not correct the problem, replace the items included in Repair Kit KK-4977. If unit leaks air at **A**, install Repair Kit KK-4977.

**ACCESSORIES**

**HAF-407 BRACKET ASSEMBLY KIT** – Used with HAF-502 and HFRL-508.

**WARRANTY**

This product is covered by DeVilbiss' 1 Year Limited Warranty.

---

**DeVilbiss Worldwide Sales and Service Listing: [www.devilbiss.com](http://www.devilbiss.com)**

---

**DeVilbiss**

DeVilbiss has authorized distributors throughout the world. For technical assistance or the distributor nearest you, see listing below.

**U.S.A./Canada Customer Service Office:**

195 Internationale Blvd., Glendale Heights, IL 60139  
Toll-Free Telephone: 1-800-992-4657 (U.S.A. and Canada only)  
Toll-Free Fax: 1-888-246-5732

**DeVilbiss Automotive Refinishing**

DeVilbiss has authorized distributors throughout the world. For equipment, parts and service, check the Yellow Pages under "Automotive Body Shop Equipment and Supplies." For technical assistance, see listing below.

**U.S.A./Canada Customer Service Office:**

11360 S. Airfield Road, Swanton, OH 43558  
Toll-Free Telephone: 1-800-445-3988 (U.S.A. and Canada only)  
Toll-Free Fax: 1-800-445-6643

**DEVILBISS®**